



# Decompression block

## HDB Series



### INTRODUCTION

Holmbury's HDB Series is a block coupling designed for the quick changeover of hydraulic attachments for skid steer loaders, compact loaders, backhoe loaders and compact utility vehicles. The decompression feature enables the operator to alleviate trapped pressure, allowing the quick and easy connection of various attachments.

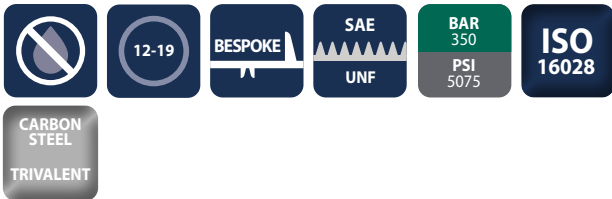

### CONSTRUCTION

- HDB block couplings are zinc nickel on body (1200 hours with no red rust in salt spray tests)
- Block body is ductile cast iron with trivalent plating
- Fitted with NBR and PTFE seals

### FEATURES

- Decompression achieved by simple pull feature which also prevents accidental system discharge
- All couplings are flat face and are designed to the ISO 16028 Standard
- Low profile coupling design minimises side loading
- Coupling arrangement can be ordered in 1/2" (Size 12) for standard flow or 3/4" (Size 19) for high flow applications
- Case drain coupling is standard 3/8" (Size 10)

### ACCESSORIES

- Not applicable

### SPECIFICATIONS

- Operating temperatures (With NBR seals): -40°C (-40°F) to 106°C (223°F)
- Maximum working pressure 350 bar
- Decompression force 130 Nm at 275 bar trapped pressure

### APPLICATIONS

- Quick changeover of construction equipment attachments
- Skid steer loaders
- Track loaders
- Excavators
- Compact loaders
- Utility vehicles

### HDB PERFORMANCE CHARACTERISTICS

Body Size	HDB12		HDB19	
	Pressure in bar - Flow in LPM			
	Pressure in PSI - Flow in GPM			
Maximum working pressure (Coupled)	350		350	
	5075		5075	
Burst pressure (Coupled)	1400		1450	
	20300		21025	
Burst pressure (Male)	1300		1100	
	18850		15950	
Burst pressure (Female)	1000		1050	
	14500		15225	
Rated flow	45		100	
	12		26.4	

# HDB Series

## HDB BLOCK ASSEMBLY

Body Size	Part Number
12 (1/2)	HDB12
19 (3/4)	HDB19

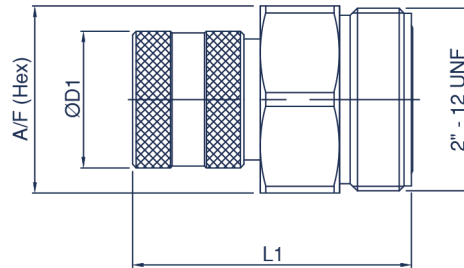
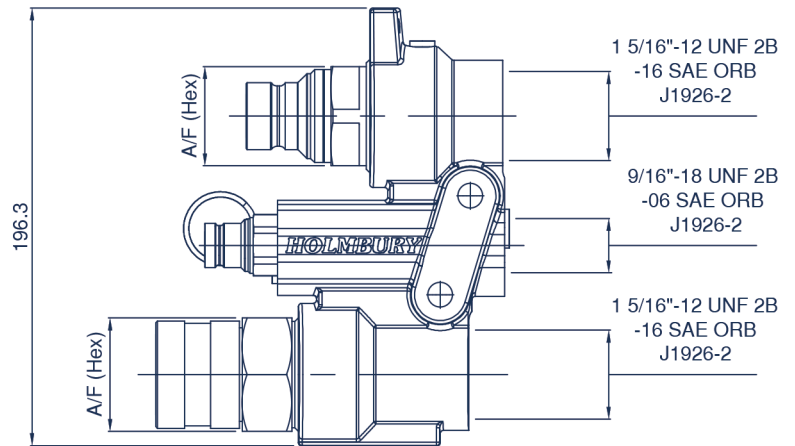
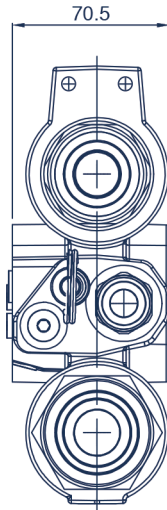

## HDB FEMALE REPLACEMENT PARTS

Body Size	Part Number	Thread Size	A/F		D1		L1	
			mm	inch	mm	inch	mm	inch
12 (1/2)	HDB12-F-24FSM	2-12 UN	51.0	2.01	38.0	1.50	70.0	2.76
19 (3/4)	HDB19-F-24FSM	2-12 UN	51.0	2.01	48.0	1.89	82.0	3.23

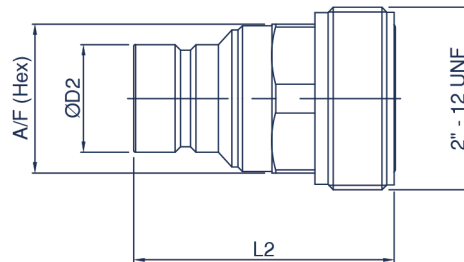
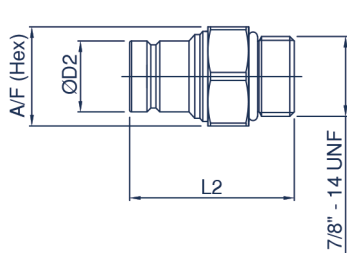

## HDB MALE REPLACEMENT PARTS

Body Size	Part Number	Thread Size	A/F		D2		L2	
			mm	inch	mm	inch	mm	inch
10 (3/8)	HDB10-M-10SM	7/8-14 UNF	25.4	1.00	19.72	0.78	46.0	1.81
12 (1/2)	HDB12-M-24FSM	2-12 UN	44.4	1.75	24.52	0.97	62.1	2.44
19 (3/4)	HDB19-M-24FSM	2-12 UN	44.4	1.75	29.93	1.18	72.4	2.85

For all other configurations or thread types please contact the sales office.