



Two-way high-pressure ball valves

BVC2 (SAE Flange Head 61/62)



INTRODUCTION

Holmbury's BVC2 Series two-way high-pressure ball valves are designed to suit a wide range of applications. These valves should not be used as flow control valves and should therefore always be fully open or closed.



SPECIFICATIONS

- Carbon steel body with trivalent plating
- Zinc alloy handle
- Forged steel option available
- Fitted with NBR and POM seals as standard
- Also available in AISI 316 stainless steel (See BVS2 Series)

FEATURES

- Floating ball design maximises sealing
- Full bore valves provide unrestricted flow path for negligible pressure drop
- Open to close in 1/4 turn
- Offset handle allows clearance for easy operation

ACCESSORIES

- Valve locking kits and valve handles are available for the BVC2 Series



CONSTRUCTION

- Operating temperatures (With NBR seals): -40°C (-40°F) to 106°C (223°F)
- BVC2 - Ball Valve - Square Body (DN12-25)
- BVC2(O) - Ball Valve - Octagonal Body (DN32-65)

APPLICATIONS

- Construction
- Mobile Hydraulics
- Test Equipment
- Machine Tools
- General Hydraulics
- Agricultural

BVC2 PERFORMANCE CHARACTERISTICS

Body Size	BVC212		BVC219		BVC225		BVC232		BVC240		BVC250		BVC265	
	FH1	FH2	FH1	FH2	FH1	FH2	FH1	FH2	FH1	FH2	FH1	FH2	FH1	FH2
	Pressure in bar - Flow in LPM Pressure in PSI - Flow in GPM													
Maximum working pressure	210	420	210	315	210	315	210	350	210	350	210	350	175	315
	3046	6092	3046	4569	3046	4569	3046	5076	3046	5076	3046	5076	2538	4569
Burst pressure	840	1680	840	1260	840	1260	840	1400	840	1400	840	1400	700	1260
	12183	24366	12183	18275	12183	18275	12183	20305	12183	20305	12183	20305	10153	18275
Rated flow	45	45	100	100	189	189	250	250	379	379	757	757	1560	1560
	12	12	26.4	26.4	50	50	66	66	100	100	200	200	416	416

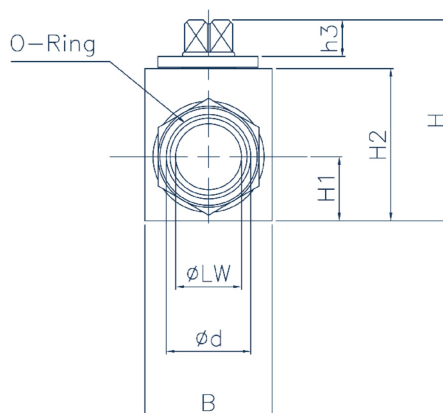
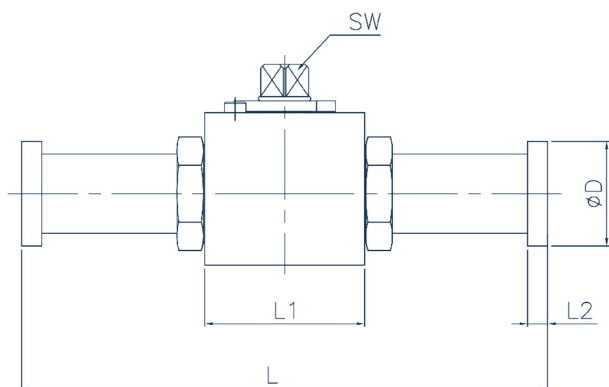

SAE FLANGE HEAD

Part Number	DN	LW	L	L1	L2	H	H1	H2	h3	B	d	D	SW
BVC2-12-FH1	12	13	151	48	6.8	52.5	17	40	8	35	25.5	30.2	9
BVC2-19-FH1	19	19	162	60	6.8	75	24	57	12	48	31.9	38.1	14
BVC2-25-FH1	25	25	178	65	8.1	82	28.5	64	12	57	39.8	44.4	14

SAE FLANGE HEAD

Part Number	DN	LW	L	L1	L2	H	H1	H2	h3	B	d	D	SW
BVC2-12-FH2	12	13	151	48	7.9	52.5	17	40	8	35	25.5	25.5	9
BVC2-19-FH2	19	19	174	60	8.9	75	24	57	12	48	31.9	41.3	14
BVC2-25-FH2	25	25	198	65	9.6	82	28.5	64	12	57	39.8	47.6	14

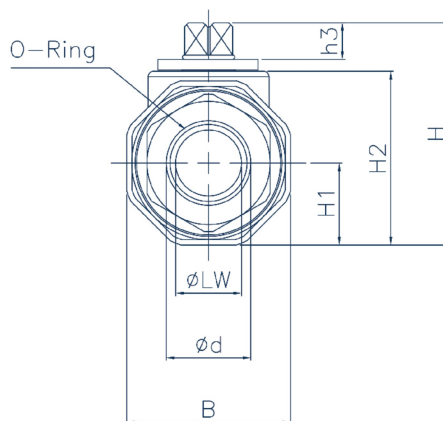
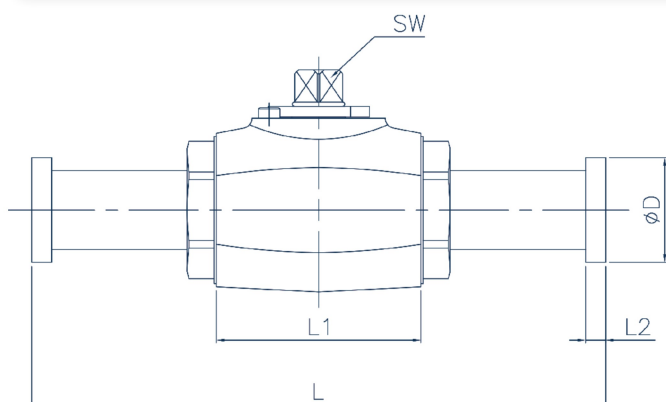

SAE FLANGE HEAD

Part Number	DN	LW	L	L1	L2	H	H1	H2	h3	B	d	D	SW
BVC2(O)-32-FH1	32	30	191	84	8.1	108	41	87.5	14	82	44.5	50.8	17
BVC2(O)-40-FH1	40	38	231	91	8.1	119.5	46.5	99	14	93	54.1	60.3	17
BVC2(O)-50-FH1	50	48	232	100	9.6	135.5	55	115	14	110	63.6	71.4	17
BVC2(O)-65-FH1	65	60	270	110	9.6	154	68.5	133.5	14	137	75.8	84.1	17

SAE FLANGE HEAD

Part Number	DN	LW	L	L1	L2	H	H1	H2	h3	B	d	D	SW
BVC2(O)-32-FH2	32	30	223	84	10.4	108	41	87.5	14	82	44.5	54	17
BVC2(O)-40-FH2	40	38	281	91	12.7	119.5	46.5	99	14	93	54.1	63.5	17
BVC2(O)-50-FH2	50	48	316	100	12.7	135.5	55	115	14	110	63.6	79.4	17
BVC2(O)-65-FH2	65	60	370	110	21.2	158	72.5	137.5	14	145	75.8	108.1	17